

ROBINET DE CUISINE À DOUCHETTE RÉTRACTABLE

PULL-OUT KITCHEN FAUCET

CARACTÉRISTIQUES SPECIFICATIONS

MAX. 2,2 GPM (8,3 LPM)
POIGNÉE À LEVIER
CORPS EN LAITON MASSIF
CARTOUCHE EN CÉRAMIQUE GARANTIE À VIE
POIDS PRODUIT: 4,8 LB (2,2 KG)

MAX. 2.2 GPM (8.3 LPM)
LEVER HANDLE
SOLID BRASS BODY
CERAMIC CARTRIDGE WITH LIFETIME WARRANTY
NET WEIGHT: 4.8 LB (2.2 KG)

CERTIFICATIONS

Les produits TASSILI adhèrent à une ou plusieurs de ces certifications :

Tassili products adhere to one or more of these certifications:



TS0421

CARLOS	FINI CHROME FINISH
3051599	TASSILI.CA



FICHE TECHNIQUE DATA SHEET



TASSILI SUPRA[®]
UN CHOIX DISTINCTIF

ROBINET DE CUISINE À DOUCHETTE RÉTRACTABLE

PULL-OUT KITCHEN FAUCET

DESSINS TECHNIQUES

TECHNICAL DRAWING

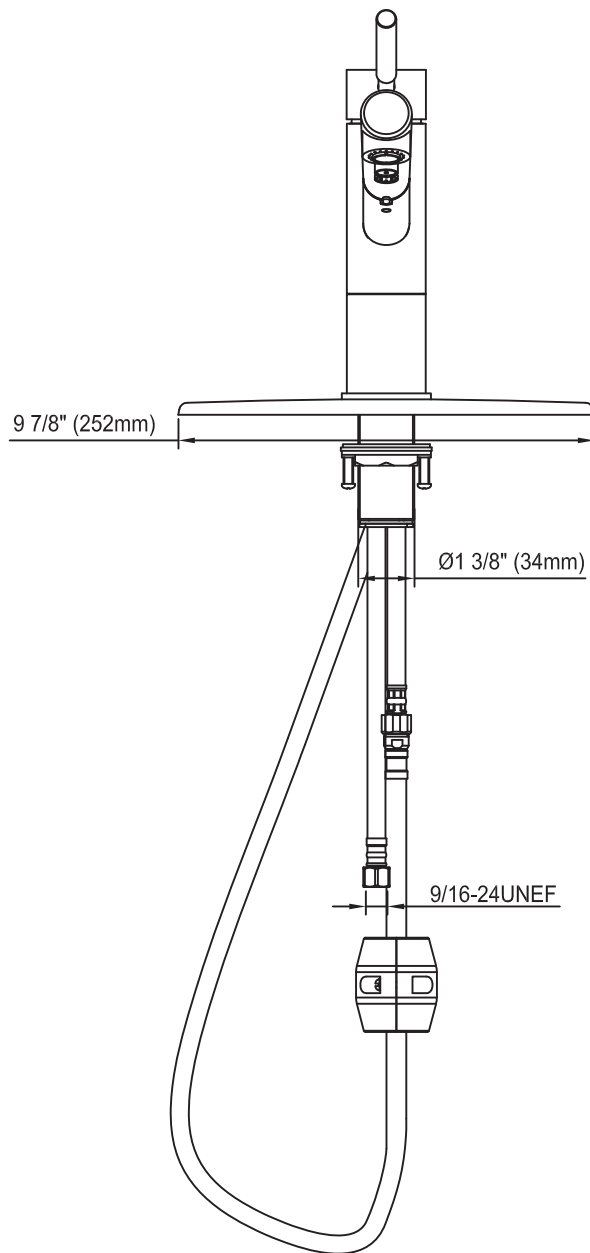
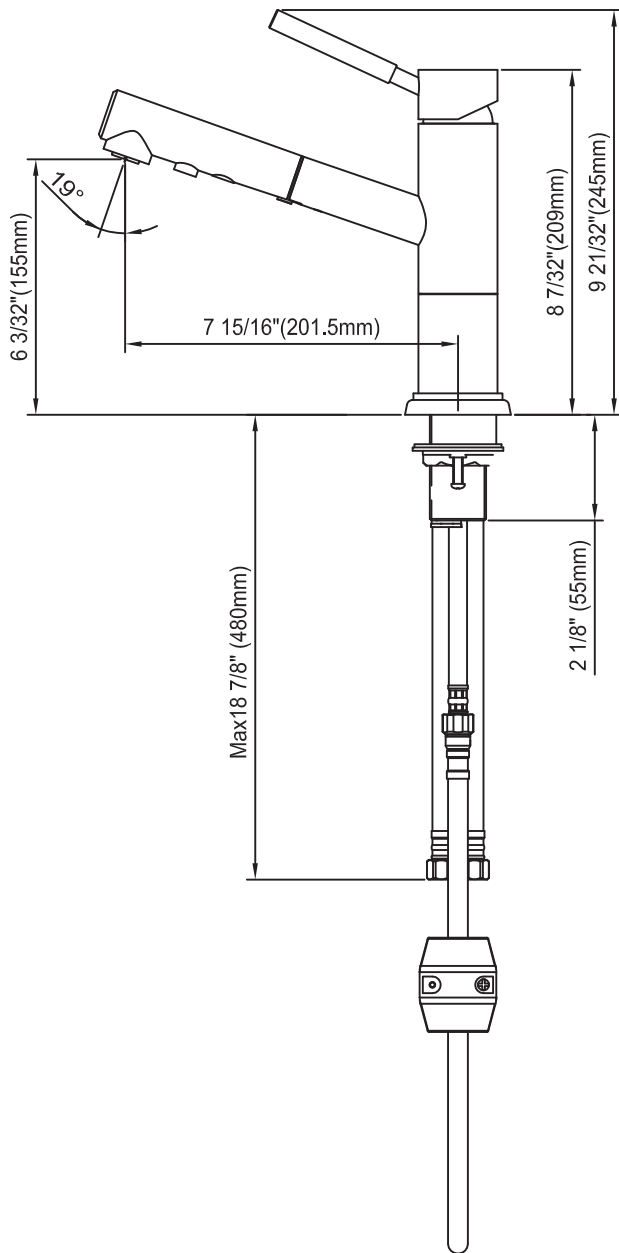

* TOUTES CES DIMENSIONS SONT APPROXIMATIVES. AFIN D'ASSURER UNE INSTALLATION PARFAITE, LES DIMENSIONS DE LA STRUCTURE DOIVENT ÊTRE VÉRIFIÉES À PARTIR DE L'UNITÉ AVANT L'INSTALLATION.

• ALL DIMENSIONS ARE APPROXIMATE. TO ENSURE PROPER INSTALLATION, VERIFY THE PRODUCT DIMENSIONS BEFORE INSTALLATION.

TS0421

CARLOS	FINI CHROME FINISH
3051599	TASSILI.CA



TASSILI SUPRA[®]