

# BAIGNOIRE AUTOPORTANTE

## FREESTANDING BATHTUB

### CARACTÉRISTIQUES

### SPECIFICATIONS

EN ACRYLIQUE RENFORCÉ DE FIBRE DE VERRE  
DRAIN ET TROP-PLEIN INTÉGRÉS  
POIDS TOTAL : 119,05 LB (54 KG)

FIBREGLASS-REINFORCED ACRYLIC  
INTEGRATED DRAIN AND OVERFLOW  
GROSS WEIGHT: 119.05 LB (54 KG)

### DIMENSIONS

66 1/8" X 29 1/2" X 22 13/16"

(168 CM X 75 CM X 58 CM)\*



DRAIN CENTRAL  
CENTRAL DRAIN



PATTES DE NIVELLEMENT  
LEVELLING FEET

### FICHE TECHNIQUE

### DATA SHEET



**TASMAN**  
33002594

BLANC  
WHITE



**TASSILI**®

TASSILI.CA

# BAIGNOIRE AUTOPORTANTE

## FREESTANDING BATHTUB

# DESSINS TECHNIQUES

## TECHNICAL DRAWINGS

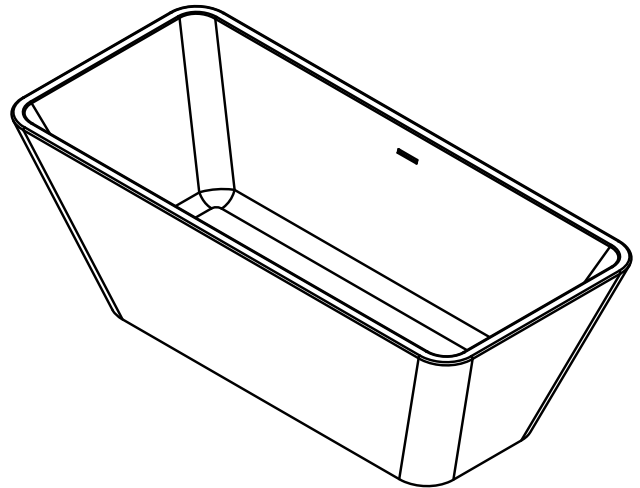
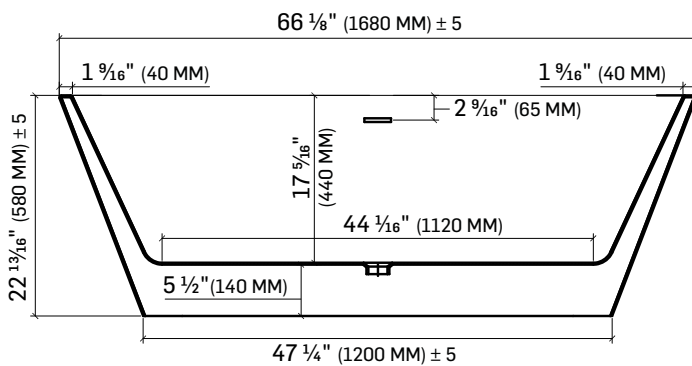
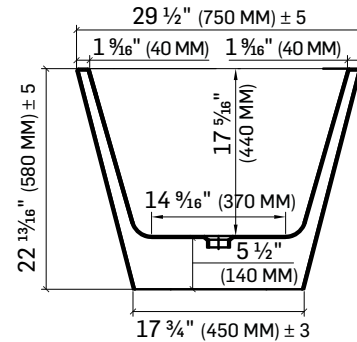
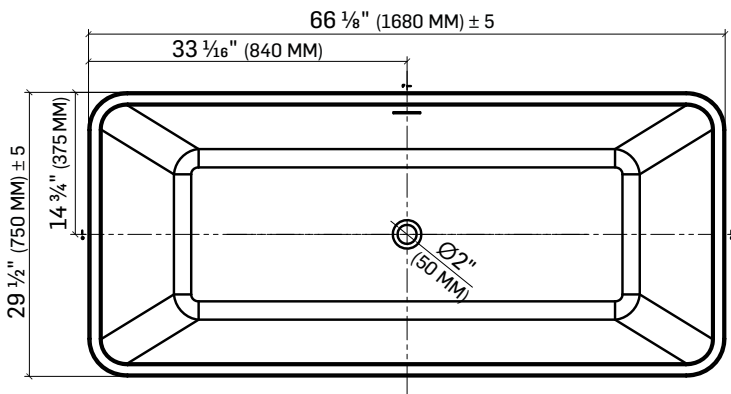

\* TOUTES CES DIMENSIONS SONT APPROXIMATIVES. AFIN D'ASSURER UNE INSTALLATION PARFAITE, LES DIMENSIONS DE LA STRUCTURE DOIVENT ÊTRE VÉRIFIÉES À PARTIR DE L'UNITÉ AVANT L'INSTALLATION.

\* ALL DIMENSIONS ARE APPROXIMATE. TO ENSURE PROPER INSTALLATION, VERIFY THE PRODUCT DIMENSIONS BEFORE THE INSTALLATION.

**TASMAN**  
33002594

BLANC  
WHITE  
T2206



**TASSILI**®