

BAIGNOIRE AUTOPORTANTE

FREESTANDING BATHTUB

CARACTÉRISTIQUES

SPECIFICATIONS

ACRYLIQUE BLANC
DRAIN ET TROP-PLEIN INTÉGRÉS
PATTES DE NIVELLEMENT
POIDS PRODUIT : 122,4 LB (55,5 KG)
GUIDE D'INSTALLATION INCLUS

WHITE ACRYLIC
INTEGRATED DRAINER AND OVERFLOW
LEVELLING FEET
NET WEIGHT : 122,4 LB (55,5 KG)
INSTALLATION GUIDE INCLUDED

DIMENSIONS

67 PO X 31 ½ PO X 23 ⅝ PO
(170 CM X 80 CM X 60 CM)*

CERTIFICATIONS

LES PRODUITS TASSILI ADHÈRENT
À UNE OU PLUSIEURS DE CES CERTIFICATIONS:

TASSILI PRODUCTS ADHERE TO ONE OR MORE
OF THESE CERTIFICATIONS:



TS0520

BOHAI	BLANC / WHITE
33001340	Fabriqué et emballé en Chine / Made and Packaged in China Importé par / Imported by NOVELCA Québec, Canada G2J1C8
TASSILI.CA	



FICHE TECHNIQUE

DATA SHEET



TASSILI SUPRA®
UN CHOIX DISTINCTIF

BAIGNOIRE AUTOPORTANTE

FREESTANDING BATHTUB

FICHE TECHNIQUE

DATA SHEET

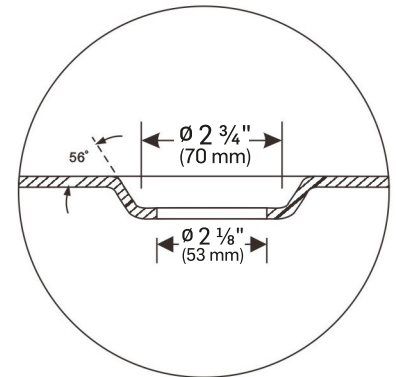
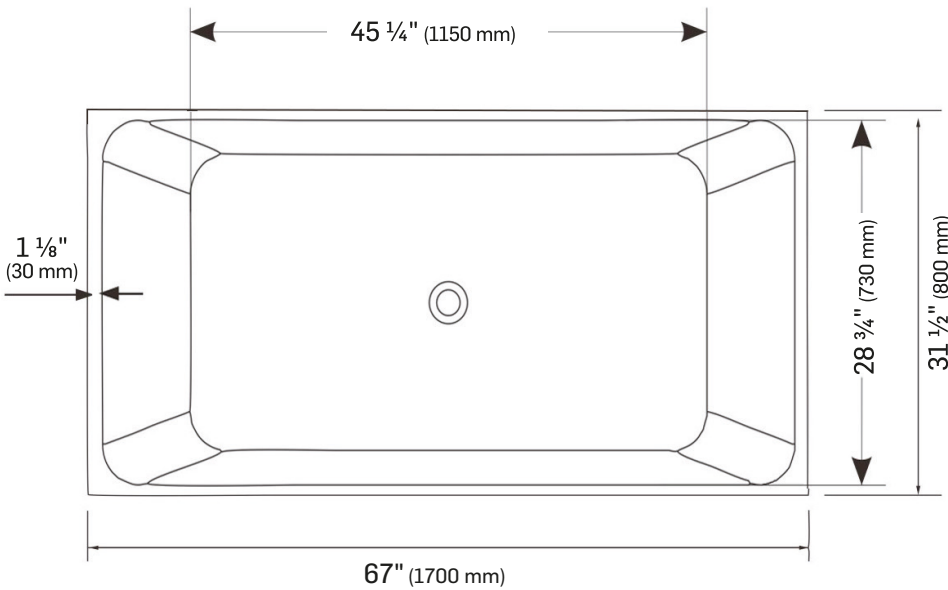
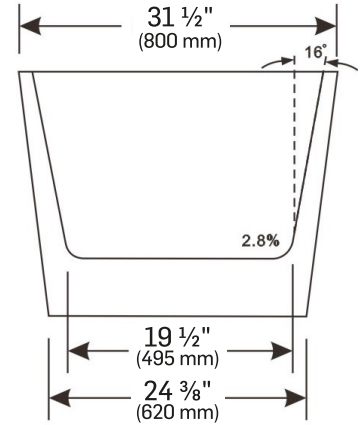
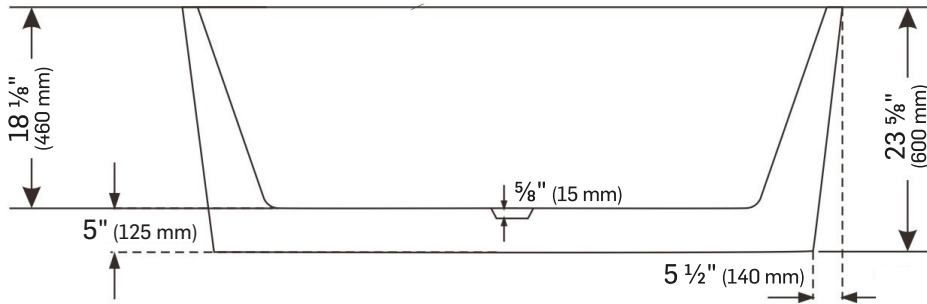

* TOUTES CES DIMENSIONS SONT APPROXIMATIVES. AFIN D'ASSURER UNE INSTALLATION PARFAITE, LES DIMENSIONS DE LA STRUCTURE DOIVENT ÊTRE VÉRIFIÉES À PARTIR DE L'UNITÉ AVANT L'INSTALLATION.
 ALL DIMENSIONS ARE APPROXIMATE. TO ENSURE PROPER INSTALLATION, VERIFY THE PRODUCT DIMENSIONS BEFORE INSTALLATION.

TS0520

BOHAI	BLANC / WHITE
33001340	Fabriqué et emballé en Chine / Made and Packaged in China
TASSILI.CA	Importé par / Imported by NOVELCA Québec, Canada G2J1C8



TASSILI SUPRA®